



- ▶ **Cost effective standard model**
- ▶ **Robust and compact design**
- ▶ **Fast response time**
- ▶ **Wide environmental temperature range**

The ETP-AM-SP-100-PT temperature probe provides a cost-effective measurement solution where heat, dust and moisture are prevalent and where a compact and robust high-reliability design is required. The sensor is particularly suitable for demanding temperature monitoring applications on vehicles but with its fast

response time and wide environmental temperature range, it is equally well-equipped for measurement of liquids and gases used in medical equipment, test machinery, industrial instrumentation and process control systems.

Specifications		
Element:	PT100B	PT1000A
Accuracy:	$\pm (0.3 K + 0,005 \times t)$	$\pm (0.15 K + 0,002 \times t)$
Working temperature:	-55°...+180 °C, short term 230 °C	
Environmental temperature:	-55°...+150°C	
Sealing:	IP67	
Response time in still water t90:	7 s	
Recommended applied current (self-heating must be considered)	1 mA at 100 Ω 0.3 mA at 1000 Ω	
Housing:	316 stainless steel	
Cable:	FEP 4 core AWG24, tinned copper shield, 3.2 mm OD	
Heat shrink:	Elastomer	

Dimensions and Wiring

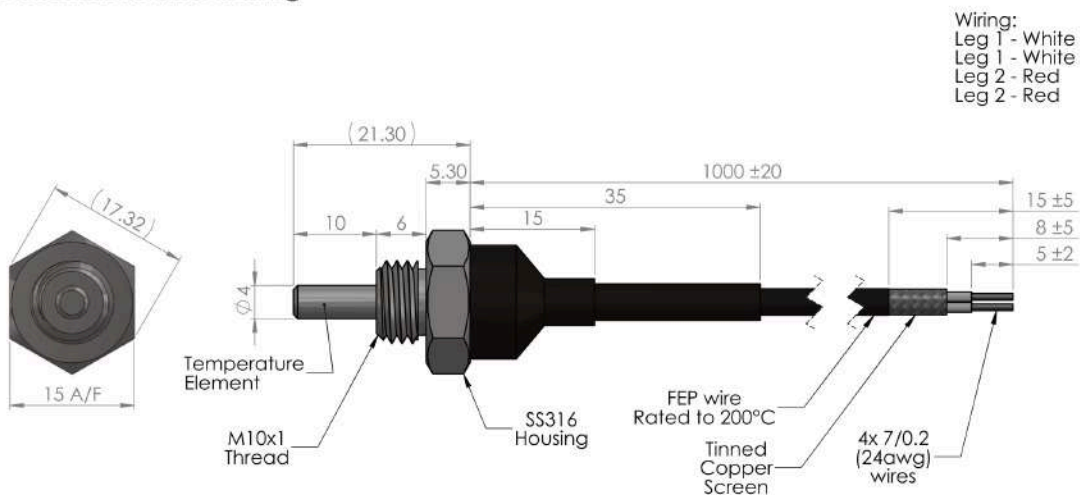

Wiring:
Leg 1 - White
Leg 1 - White
Leg 2 - Red
Leg 2 - Red

Order Code 93629-ETP-AM-SP-100-PT100B
 93637-ETP-AM-SP-100-PT1000A