



- ▶ **Low profile, rear hinged switch designed for improved user comfort**
- ▶ **All plastic construction with raised tread pattern and anti-slip pad**
- ▶ **Innovative design make it an ideal product for OEM use**

Specifications	
Standards/ approvals	Footswitch: low voltage directive 2017/35/EU, EN 60950
Degree of protection	EN 60529 IPX2
Connection method	Solder tag microswitch, no cable fitted (max cable diameter 5.5mm)
Electrical rating	6A 250V AC
Contact configuration	SPCO (Single pole changeover), Momentary action
Operating temperature range	-20°C to +60°C
Body material	Thermoplastic
Weigh	0.12 kg
Additional Information	Black cover, black base



## Dimensions

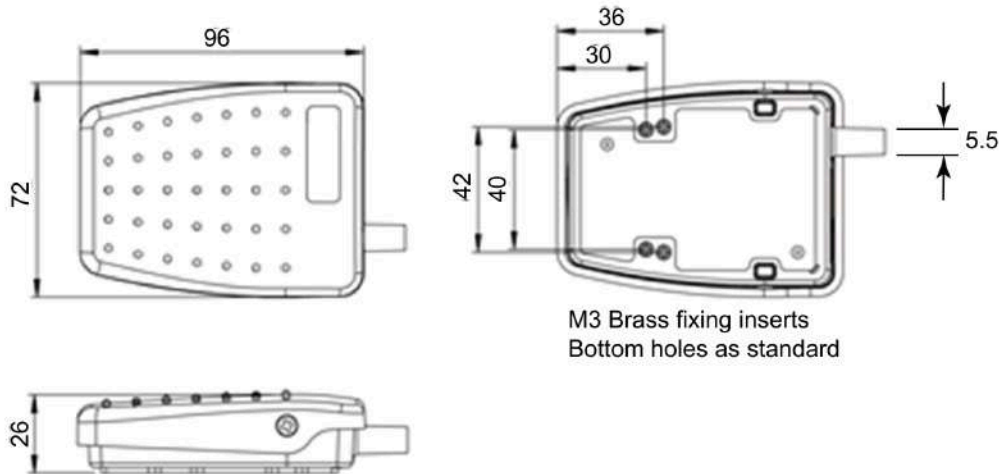

## Accessories

Part Number	Description
6202-0001	Single black, RAL 9005 guard
6202-0002	Single gray, RAL 7035 guard
6202-0003	Twin Grey, RAL 7035 guard



Minimum delivered batch quantities - 100 pcs